

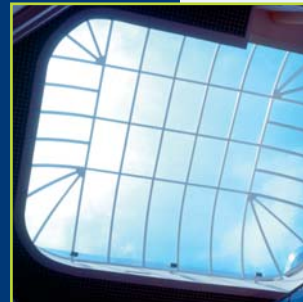

SUNGLAZE™

Polycarbonate Architectural
Roofing System



Technical Handbook

Content

Overview	2
Product definition	2
Features and Benefits	2
Typical Applications	2
Sizes	2
Drawing	2
System & Accessories	3
Loads and Spans	3
Installation	4
Safety, handling & storage, cutting	4
Notes, cleaning	5
Details	5
Properties	6
Color & Light Transmission	7
Thermal insulation	7
UV resistance	8
UV protection	8
Chemical resistance, Flammability, Acoustic properties	9
Contact details	10





Overview

SUNGLAZE is an innovative architectural glazing system with an elegant design and appearance. It offers high versatility, low maintenance and a sustainable design for various architectural challenges. SUNGLAZE incorporates standingseam profiling and glazing that enable ultra-wide spans. It can be specified in various lengths to match various structures.

Product Definition

A new Glass Look architectural system, offering the widest range of dimensions, shapes and colors. The system is based on a special design of Polycarbonate panel clamped with a new developed aluminum system. SUNGLAZE system is designed to be installed on rafters or purlins.

Features and Benefits:

- Glass-like elegant appearance
- Standing seam system
- Thermal expansion free
- Leak-proof
- Caulking and silicone free
- Withstand very high loads
- Easy, fast and safe installation
- Low maintenance

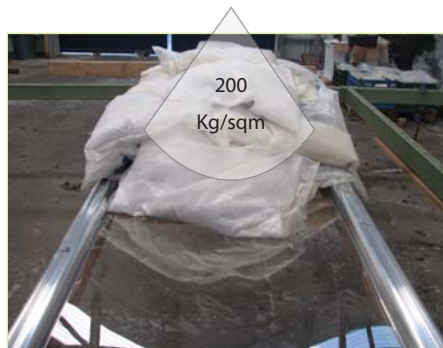

Typical Applications:

- Architectural structures
- Commercial and retail
- Sport facilities
- Covered walkways
- Open markets
- Service stations
- Entrances
- Pool covers



SUNGLAZE™ Sizes:

#	Thickness (mm)	Width (mm)	Length (m)
1	3	400 to 700	1.5 to 12
2	4	400 to 800	1.5 to 12

* Custom dimensions may be available upon request

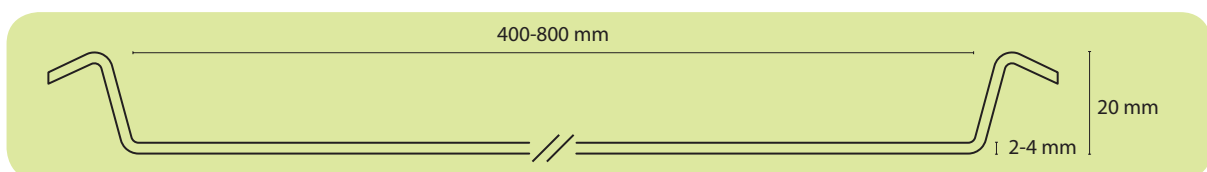

System & Accessories:

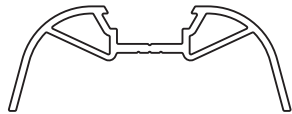
#	Item	Drawing
1	Cup Plug	
2	Cup	
3	Base	
4	Screw 1-1/4", stainless steel, Self drilling.	

Max. Spans Between Purlins (mm):

Section Dimension (mm)	Single Span			Multi Span		
	75 (kg/m ²)	100 (kg/m ²)	125 (kg/m ²)	75 (kg/m ²)	100 (kg/m ²)	125 (kg/m ²)
3/700	1600	1450	1400	2000	1850	1750
4/800	1650	1500	1400	2050	1900	1750

* Tested at deflections 5% of width.





Installation:

SUNGLAZE can be installed on purlins or rafters structure.

Installation is fast, easy and safe, as can be seen in the drawing below.

- a. Lay aluminum base on purlin.
- b. Attach aluminum base to purlin by the screw.
- c. Lay Polycarbonate panels in place.
- d. Lay aluminum Cap in line.
- e. Attach aluminum Cap with screw
- f. Lay and clip aluminum Cap Plug.

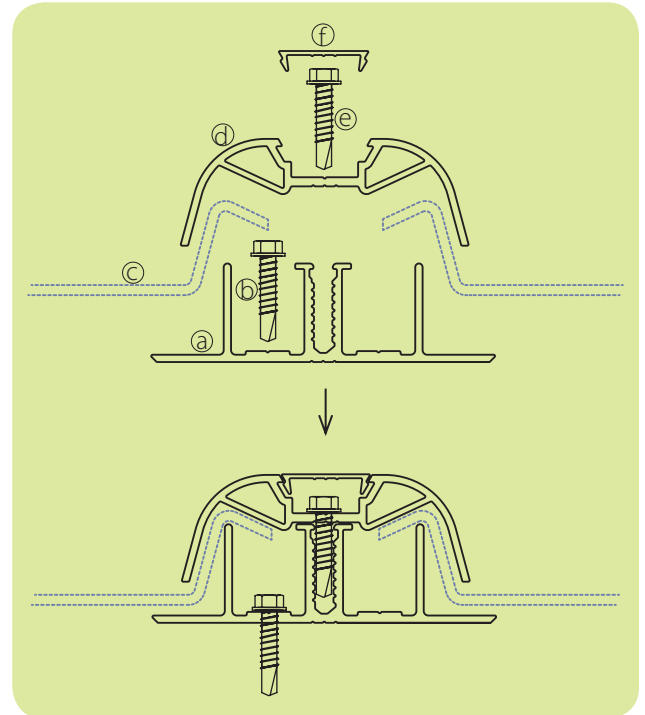

Fastening Tips:

Use adjustable electric screwdriver. The screw must be installed perpendicular to the Panel and Aluminum profile.

Safety:

- Do not step directly on the panels.
- Work according to local safety regulations.

Handling and Storage:

- Store in a shaded place, protect from direct sunlight and rain.
- Avoid covering the panels with heat absorbing materials.
- Avoid contact or environment of chemicals.
- Protect the panels from any damage.

Sawing and Cutting:

- SUNGLAZE panels can be cut with bandsaws, handsaws, circular saws and other cutting tools. Not with standing the
- multiple possibilities, the table below indicates the cleanest cutting options.

#	Circular Saw	Bandsaw
Clearance Angle	20° - 30°	20° - 30°
Flake Angle	15°	0.5°
Cutting Speed	180 – 250 m/min	200 – 250 m/min
Blade / Band Speed	1800 – 2400 m/min	600 – 1000 m/min
Tooth Spacing	2 – 5 mm	1.5 – 2.5 mm

Important Notes:

Be sure to install the UV protected side facing out. In cases when the system might be directly exposed to sunlight please ask for UV protection on both sides of the panel.

Avoid any stress source.

Avoid contact with chemically incompatible materials.

Use only approved accessories, including washers, silicones, sealing tape, closure fixtures etc. Soft PVC washers simulating EPDM washers are not approved for use with Polycarbonate sheets.

Cleaning:

SunGlaze panels can easily be cleaned with a soft cloth made from 100% cotton using generous amounts of detergent and water.

It is best to use mild dish cleaning preparations.

Commercial spray cleaners are available. Please consult with your local PALRAM agent or representative for recommended commercial preparations available locally.

Accessories:

When necessary use only approved Accessories.

Details:

Wall and Roof Trim

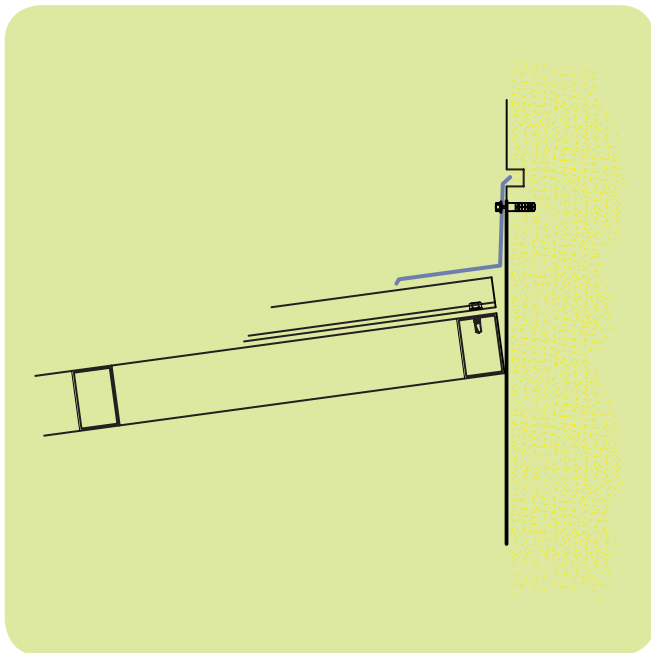

Gutter

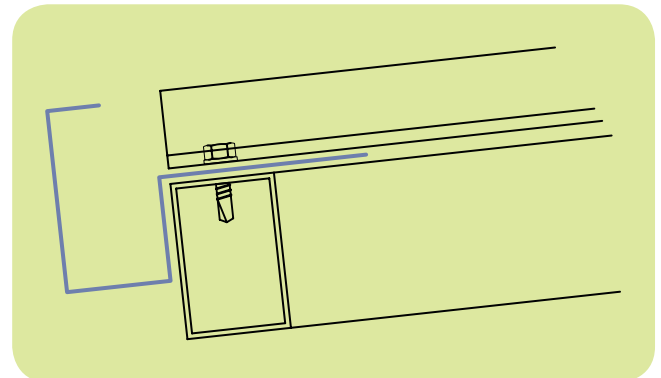

Side Trim

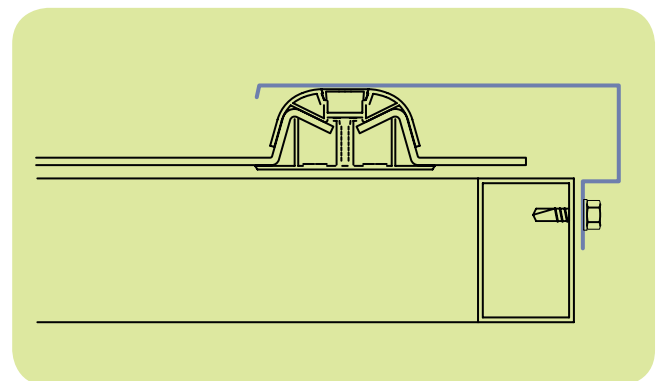



Typical Properties:

Property	Conditions	ASTM	ISO	Units	Value
Density Physical		D-1505	R 1183	g/cm ³	1.2
Tensile strength at yield	10 mm/min	D-638	R 527	MPa	62
Tensile strength at break	10 mm/min	D-638	R 527	MPa	65
Elongation at yield	10 mm/min	D-638	R 527	%	7
Elongation at break	10 mm/min	D-638	R 527	%	>80
Tensile Modulus of Elasticity	1 mm/min	D-638	R 527	MPa	2300
Flexural Strength Mechanical	1 mm/min	D-790	178	MPa	93
Flexural Modulus	1.3 mm/min	D-790	178	MPa	1890
Izod Impact Strength Notched	23 °C	D-256	R 180	J/m	800
Impact Falling Weight	0.8 mm		6603	J	50
Rockwell Hardness		D-785	2093-2	R scale	118
Long Term Service Temperature				°C	-50 to +100
Short Term Service Temperature				°C	-50 to +120
Heat Deflection Temperature	1.82 Mpa	D-648	75	°C	135
Vicat Softening Temperature Thermal Load:	Load: 1 kg	D-1525	306:2004	°C	150
Coefficient of Linear Thermal Expansion		D-696		10 ⁻⁵ /°C	6.5
Thermal Conductivity		C-177		W/m K	0.21
Specific Heat Capacity		C-351		kJ/kg K	1.3
Haze Clear	Clear	D-1003		%	<0.5
Optical Light Transmission Clear	Clear	D-1003		%	~90

* Properties in the table relate to the polycarbonate glazing portion of SUNGLAZE

** ASTM method except where noted otherwise

Colors and Light Transmission

SUNGLAZE is available in a wide variety of transparent and translucent colors. Opal or translucent panels have 20% to 80% light transmission, depending on thickness and structure of the panel. Tinted and Solar Control panels transmit fixed amounts of light (20, 35, or 50%). The heat transmission is also reduced. (Custom colors are available contingent on a guaranteed minimum order.). A list of standard colors appears below. It is recommended that you requested a sample chips to obtain an accurate representation of the color(s) in question.

Color	%LT	%Haze	SC
	ASTM D-1003	ASTM D-1003	ASTM E-424-71
Clear	90	<1	1.00
Bronze	20	<1	0.52
Solar Grey	20	<1	0.51
White Opal	28	100	0.35
Solar Control	20	67	0.42
White Diffuser	80	100	1.00
Solar-Smart Green	18	102	0.32
Solar Smart Grey	20	30	0.45
Solar Smart Blue	19	64	0.35

Thermal Insulation

On very hot days, the surface temperature of the sheet might reach up to +50°C (+122°F). The “U” value characterizes the degree of thermal transmittance offered by a given glazing material (Higher “U” values are associated with materials that are poor insulators, resulting in a greater loss of heat). The following table compares the “U” values of glass and SUNGLAZE of equivalent thicknesses. (Thicker sheets of a given material will offer greater thermal insulation and be characterized by a lower “U” value and reduced heat loss.). For any given thickness, the “U” value of SUNGLAZE is lower than that of glass. Therefore, the heat loss from the building interior and penetration of heat or cold into a building glazed with SUNGLAZE will be less than for one glazed with glass. This can result in a significant reduction in energy expenditure both for heating in winter and air-conditioning during the summer. Note that use of Solar Control sheets will insulate just as well and will also reduce air-conditioning costs because of less heat penetration.

Thickness (mm)	SUNGLAZE U Value (W/m ² *0K)	SUNGLAZE U Value (W/m ² *0K) 3 3
3	5.47	5.81
4	5.31	5.76





UV Resistance

Integrated co-extruded UV protection enables Palram polycarbonate panel to retain its transparency without yellowing as well as its mechanical properties throughout a long lifetime of service. The protection will not peel or wear away over time.

The following graph present representative results from SUNGLAZE tested under simulated UV exposure that is equivalent to 20 years of actual exposure. The light transmission of SUNGLAZE was essentially unchanged. The small increase in yellowness index depicted in the graph below is not visible to the human eye.

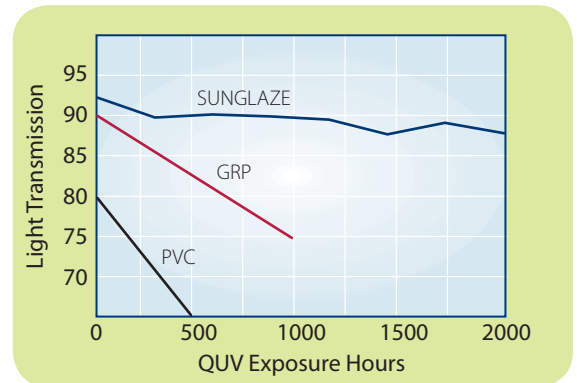

Palram Polycarbonate Panel Protects against the Harmful Affects of UV Radiation

Exposure to solar ultraviolet (UV) radiation is becoming a major health concern. The adverse affects were once thought to be associated with solar UV radiation in the 270 to 320 nm (UV-B) range. However, in recent years it has become apparent to exposure to UV-A (320-400 nm) is also detrimental. In addition to skin cancer, premature aging has been associated with exposure to UV-A. SUNGLAZE panels totally block out UV radiation in this portion of the spectrum. Almost all the UV-A radiation is also blocked out. This almost total blockage of UV radiation can be observed in the figure below.

A comparison of the UV protection offered by SUNGLAZE and that offered by sunscreen is depicted in the graph above.

Note that no barrier is as effective as SUNGLAZE panel. Activity below Sun glaze will be more protected than that offered by proper application of sunscreen, though the latter is sufficient in almost all cases. The key word in the previous sentence is proper. Improperly applied sunscreen or forgetting to apply skin screen will result in undesirable levels of exposure. In addition, note that protection factors are computed on the basis of UV-B exposure. There is as yet no way to compute protection to UV-A exposure. It should also be noted that formulations are still being marketed which only block out UVB. When playing or swimming below SUNGLAZE, protection is always complete. When swimming, there is no danger that the protection will be washed away. In the last ten years, it has also been documented that UV exposure can also cause damage to the eyes, specifically to the cornea. Wearing sunglasses manufactured from polycarbonate protects the eyes. However, most people remove their glasses when entering the pool. This is a factor for both public and private pools to consider when contemplating a choice of covering.



Chemical Characteristics

To obtain a wide listing of our polycarbonate products behavior with chemical agents please ask from PALRAM.

Flammability

The flammability classifications of Sunglaze is based on tests carried out by certified independent laboratories, are listed below by standard. All presented certificates were tested with Polycarbonate solid which is a standard product at PALRAM. Sunglaze is produced based on similar technology and raw materials.

Standard	Classification
NSP 92501,4	M2 (1.5 – 12 mm)
BS 476/7	Class 1
DIN 4102	B1, B2
CSE RF 2/75/A CSE RF 3/77	Class 1
UL Classified	V2 (File e221255)
ASTM D-635	CC1

Acoustic Properties

Sunglaze panels have excellent sound insulation properties as indicated in the table below. The ability to absorb sound waves together with its impact resistance, has made Sunglaze the material of choice for cladding.

Thickness (mm)	Acoustic Insulation DIN 52210-75 RW (db)
3	23
4	24

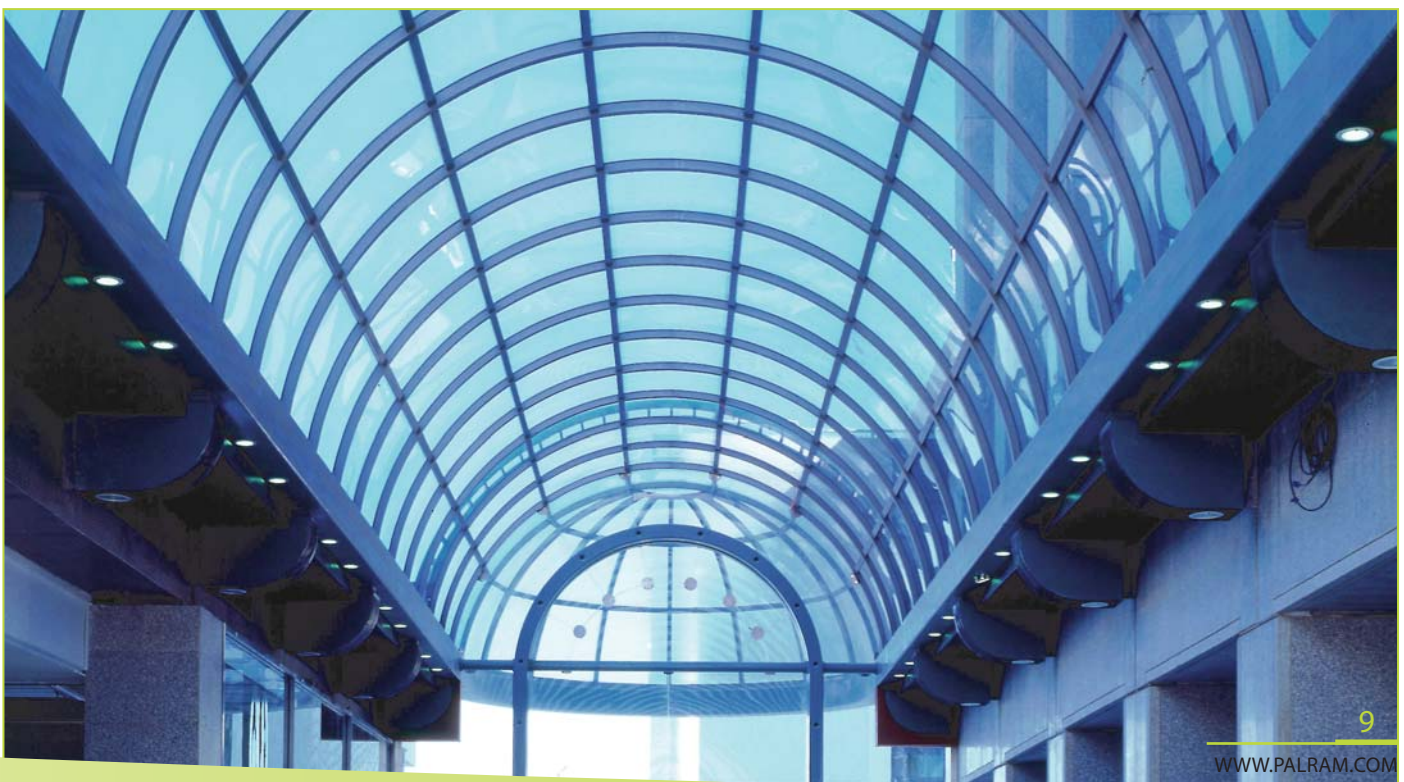

Contact Details:

PALRAM Headquarters

PALRAM Industries Ltd.
Kibbutz Ramat-Yohanan 30035, Israel
Tel: (972) 4-845-9900
Fax: (972) 4-844-4012
palram@palram.com

South-America

Marcelo Saroka
Tel / Fax: (972) 4 6392889
Mobile: (972) 528 745851
marcelosaroka@gmail.com

PALRAM Europe Ltd.

Unit 2, Doncaster Carr Industrial Estate
White Rose Way, Doncaster DN4 5JH
United-Kingdom
Tel: (44)-1302-380776
Fax: (44)-1302-380788
palram@palram.co.uk

PALRAM France Ltd.

Batiment A, 14-16oulevard Arago
91320 Wissous, France
Tel: (33)-1-69534179
Fax: (33)-1-69305013
palram.france@palram.com

Central-America

Mikershy S.A., Apdo Postal 625-1250
Escazu, Costa Rica
Tel: (506) 289 79 57
Fax: (506) 228 93 12
mliebembuk@racsa.co.cr

PALRAM Italy

Via Indipendenza 48
27100 Pavia, Italy
Tel: (39)-0382-539691
Fax: (39)-0382-24555
roaluffi@tin.it

PALRAM Hong-Kong Ltd.

Rm. 1206-7, 12/F New Victory House
93-103 Wing Lok Street, Central,
Hong-Kong
Tel HK: (852) 9841-1914
Fax: (852) 3000-35428
sales.hk@palram.com

PALRAM Australia PTY Ltd.

252 Boyce Road, Maroubra
NSW 2035, Australia
Tel: (61)-2-83472778
Fax: (61)-2-83472779
Mobile: (61)-410-404247
talila.horesh@palram.com

PALRAM Americas Inc.

9735 Commerce Circle
Arcadia West Industrial Park
Kutztown, PA 19530, USA
Tel: (1) 610-285-9918
Fax: (1) 610-285-9928
palramamericas@palram.com

PALRAM United-Kingdom

Unit 2, Doncaster Carr Industrial Estate
White Rose Way, Doncaster DN4 5JH
United-Kingdom
Tel: (44)-1302-380738
Fax: (44)-1302-380739
sales@palram.co.uk

PALRAM Beijing

A410 Huaxin Mansion, 33 An Ding Road
Chao Yang District, Beijing
China 100029
Tel: (86)-10-51209077
Fax: (86)-10-51209078
sales.beijing@palram.com

PALRAM Germany

Westönnner Hellweg 11
D-59457 Werl, Germany
Tel: (49)-2922-860410
Fax: (49)-2922-909395
palram.germany@palram.com

PALRAM Asia

Manhattan House 151
Chin Swee Road Singapore 169876
Tel: (65)-62357074
Fax: (65)-62353321
htlimd@singnet.com.sg

PALRAM Japan

2-22-6, Fujishiordai
Suita City, Osaka 565, Japan
Tel: (81)-6-68336248
Fax: (81)-6-68336248



FEEL FREE TO VISIT OUR WEBSITE FOR MORE INFORMATION AT WWW.PALRAM.COM

Inasmuch as PALRAM Industries has no control over the use to which others may put the material, it does not guarantee that the same results as those described herein will be obtained. Each user of the material should make his own tests to determine the material's suitability for his own particular use. Statements concerning possible or suggested uses of the materials described herein are not to be construed as constituting a license under any PALRAM Industries patent covering such use or as recommendations for use of such materials in the infringement of any patent. PALRAM Industries or its distributors cannot be held responsible for any losses incurred through incorrect installation of the material. In accordance with our company policy of continual product development you are advised to check with your local PALRAM Industries supplier to ensure that you have obtained the most up to date information.